



LUX-IDent
RFID Inlays & Labels Manufacturer

General RFID label Delivery and Packaging specification

V1.1
25.06.2019



...tuned to your frequency



General RFID label Delivery and Packaging specification

Dear Customer,

Thank you for choosing LUX-IDent as your supplier for high quality RFID labels.

This document provides important information and technical data about packaging, shipping and compliances.

Content

1	Product description	3
2	RFID Label specification	3
3	RFID label product code	3
4	Tape configuration	4
	4.1 Leader and trailer tape.....	4
	4.2 Splices	5
5	RFID Label testing and marking.....	7
	5.1 RFID Label testing	7
6	Technical data	7
7	Shipping and Packaging	8
	7.1 Reel.....	9
	7.2 Packaging for shipment	9
8	Reel and box labeling	11
9	Storage and handling.....	12
10	Document revisions	13



General RFID label Delivery and Packaging specification

1 Product description

LUX-IDent RFID labels are mostly customized and application specific products which have been designed for a particular applications. Beside these specialized RFID labels LUX-IDent offers also a variety of standardize RFID labels.

2 RFID Label specification

LUX-IDent provides a technical specification drawing for each type of RFID label. The drawing contains detailed information about the label dimensions, positioning of the RFID label on the liner and the RFID label construction. Additional information about the roll configuration and unwinding direction are also given.

The technical drawing will be provided during the product definition phase or can be requested from the LUX-IDent customer service via email sales@lux-ident.com or smart-inlay@lux-ident.com.

3 RFID label product code

Each LUX-IDent RFID label has its unique product code for the particular definition of its characteristics and features. The following explanation shows the setup of the product code:

L3x-CDDMDD-CHP-REFER-ECCXX

Product group L3x HF, UHF or combi label	Dimensions CDDMDD RFID label dimension and orientation	CHP Chip type used for this label	REFER Reference to label construction	ECCXX Optional information about encoding
--	--	---	---	---

4 Tape configuration

RFID labels are delivered on reels.

4.1 Leader and trailer tape

For standard deliveries, no leader and trailer tape is added to label liner. One layer of empty liner material is wrapped around the outer label winding to protect the labels against contamination and keep the roll closed.

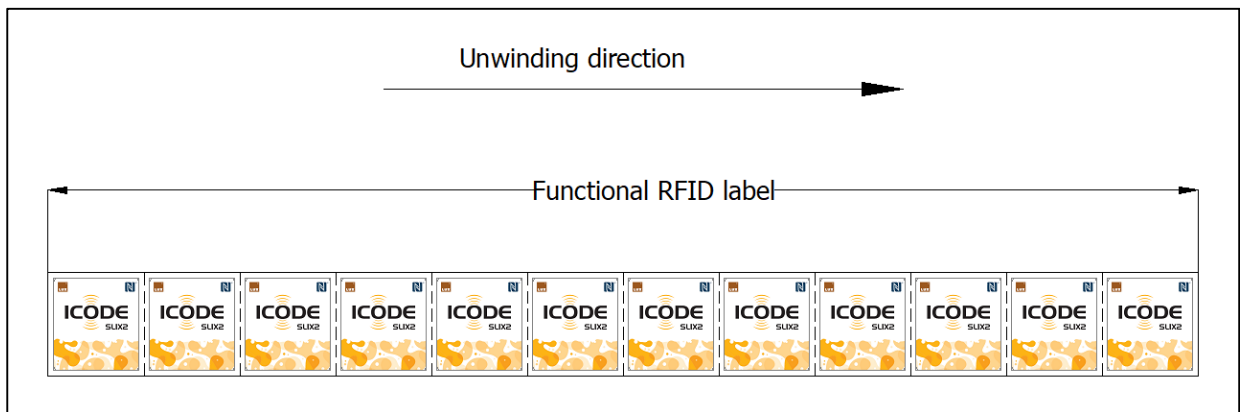

Figure 1: Example of standard RFID label delivery on roll

4.2 Splices

RFID label tapes may have splices within a roll. Splices at the end of raw materials are made by the suppliers of the raw material or by LUX-IDent during the label production process. Splices made by our suppliers are out of our control and are made by the internal rules of our suppliers. Therefore the type or the splicing tape may differ to our internal specification.

The following rules apply to the splicing of label tapes made by LUX-IDent:

- Splicing is done at a non-specific position at the raw materials. Due to the nature of the production process a splice can't be made at a defined position. Depending on the RFID label size and RFID label pitch in machine direction, one or more RFID labels are affected by the splice.
- LUX-IDent uses a 88 µm thick, green splicing tape to join the materials. A specification of the splicing tape can be provided on request.

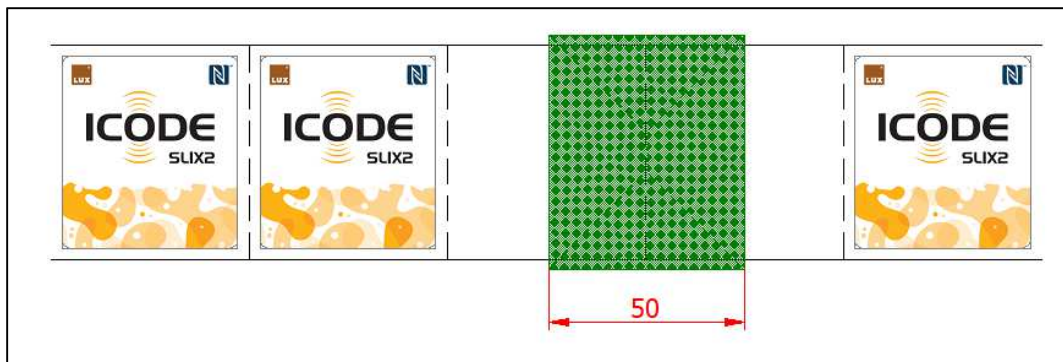

Figure 2: Splice of liner with test option "Removal of defect labels"

The splicing tape is applied on:

- Liner material: only on back side
 - Faces stock material: only on top side
 - Other materials: on both sides of the material
- The static pull force of a splice is specified at minimum of 50 N for a 50 mm wide tape at room temperature. The characteristics of splices made by our raw material suppliers may differ.
 - Splicing tape edge cutting:

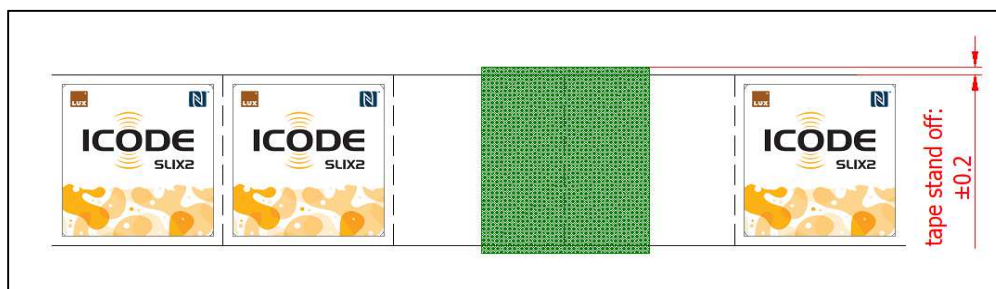

Figure 3: Splicing tape maximum stand off

■ Pitch tolerance

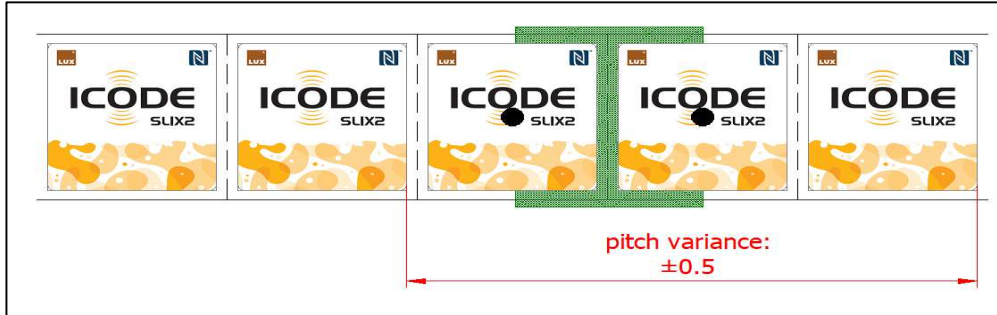

Figure 4: Pitch tolerance at splicing positions

■ Maximum allowed angular failure

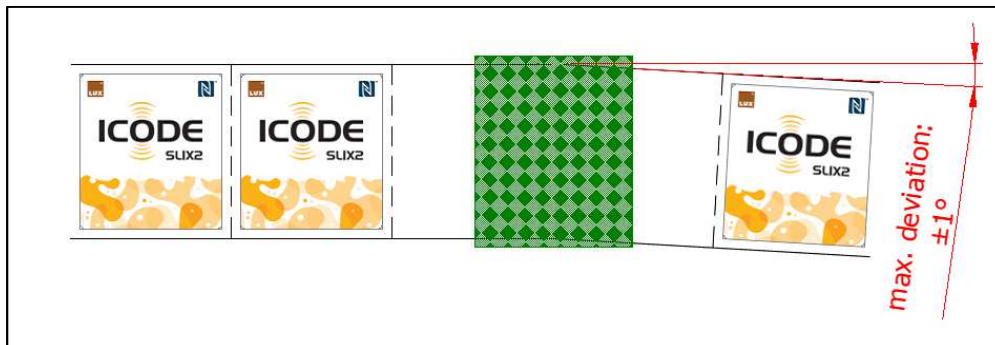

Figure 5: Maximum angular failure at splicing position

LUX-IDent takes care that labels at splicing positions are marked as non-functional. Due to the nature of the R2R production process and the type of splicing tape used by our raw material suppliers it can happen that some splicing positions will not be detected and marked.

5 RFID Label testing and marking

5.1 RFID Label testing

LUX-IDent RFID labels undergo a 100% inline Go/NoGo test during the label production process or in an extra off-line test run. Treatment of non-functional RFID labels is defined in the respective RFID label drawing. LUX-IDent offers the following options:

- Marking with a black dot or text



Figure 6: Marking of non-functional RFID labels

- Removal of non-functional RFID labels where empty positions remain on the liner

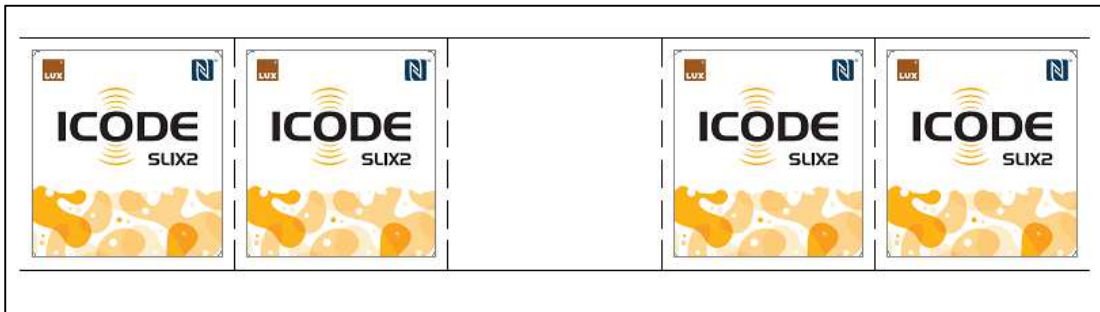

Figure 7: Removal of non-functional RFID labels

- Replacement of non-functional labels by functional labels. This requires larger positioning tolerances of the labels on the liner and will be noted on the label specification drawing.

6 Technical data

Technical data of RFID label are always product specific and depend on the materials involved. Please refer to the technical drawings for detailed information about the RFID label.

7 Shipping and Packaging

RFID labels from LUX-IDent are produced in a Reel-to-Reel conversion process and delivered on cores made of cardboard. All rolls are hanging on a core tube and are protected by corrugated paper side walls. This protects the RFID labels from damage during transport and handling. The RFID label rolls and the protective packaging is placed inside a closed PE bag together with some silica gel bags for moisture absorption. The rolls are packed in sturdy corrugated paper shipping boxes for safe transport from factory to customer.



Figure 8: Label rolls packed into PE bag and shipping carton

7.1 Reel

RFID labels will be delivered as roll on a cardboard core with 3" inner diameter. The outside diameter is depending on the number of RFID labels on one roll and is limited to 350mm.

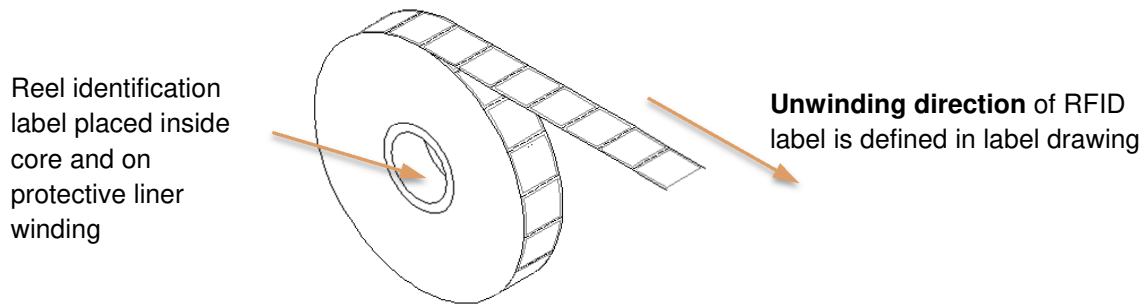

Figure 9: RFID Label roll without flanges

RFID labels on a narrow liner or with asymmetric construction will be delivered on reels with flanges. This gives additional protection to the RFID labels and prevents collapsing of the roll.

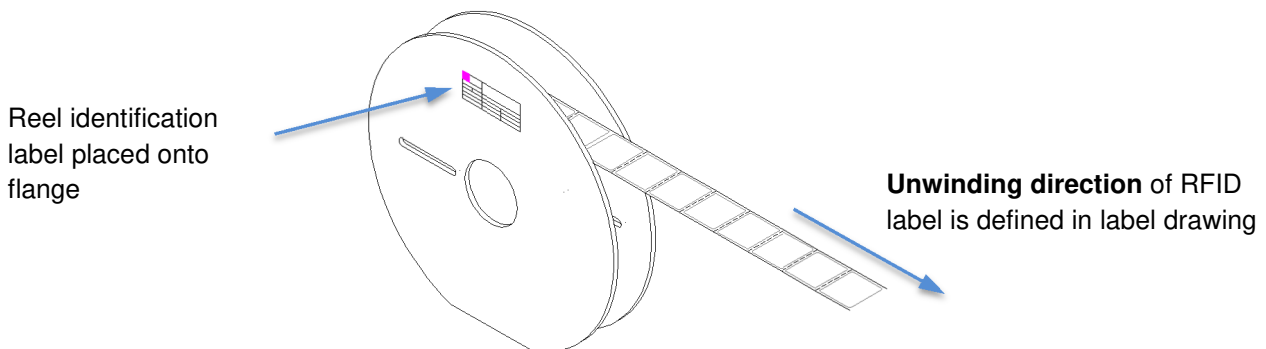

Figure 10: Label delivery on reel with flanges

7.2 Packaging for shipment

Depending on RFID label size, chip size and customer requirements the quantity of RFID labels per reel will vary. The amount of good RFID labels per reel is specified in the according technical drawing and belongs to all reels of a production batch, except the last one. The last reel is used to finish the production order and volumes will vary. Please note, that due to the Reel-to-Reel production process LUX-IDent is not able to deliver the exact quantity as ordered. LUX-IDent reserves the right to over / under deliver max. 10% of the total ordered volume as mentioned in the General Terms and Conditions.



General RFID label Delivery and Packaging specification

Reel dimension	The outside diameter of the label roll is depending on the number of labels per roll and is specified at the label drawing.		
Reel core diameter	76,2 mm (3") , see also technical drawing		
Minimum winding diameter	110 mm		
Reel width	<p>Equal to the specified liner width. The paper core width corresponds to the liner width with a tolerance of ± 1 mm.</p> <p>For RFID labels delivered on rolls with flanges the reel widths equals liner width plus 15 mm ± 2 mm</p>		
Cardboard shipping box dimension	Max. reel diameter	Multi box with max. 6 reels	Shipping weight
	Ø 250 mm	400 x 300 x 315 mm	max. 15 kg
	Ø 350 mm	400 x 400 x 415 mm	max. 25 kg
Minimum yield:	> 98% average yield per production batch of more than 20.000 inlays.		

8 Reel and box labeling

Each RFID **label reel** is labeled with an identification label showing all relevant data such as:

- Product description and article code
- Batch number and reel number
- Production date
- Quantity of good and bad inlays on reel

		Article name: HF-Label 5x38mm, Pitch 42,33mm, ST25TV02k HC, one lane	
		Article code: 570 / L35-005038-SV1-STE00	
Batch No.	Reel No.:	19/8565	01
Date:		22.05.2019	
Quantity good pcs:		2000	
Quantity bad pcs:		20	

Figure 11: Example of Label per reel

Each **shipping box** is marked with a label showing the following information of the reels contained in the box:

- Product description and article code
- Batch number and reel numbers inside box
- Production date
- Box number of whole shipment
- Quantity total of good and bad inlays/labels contained in box.

		Article name: HF-Label 5x38mm, Pitch 42,33mm, ST25TV02k HC, one lane	
		Article code: 570 / L35-005038-SV1-STE00	
Batch No.	Reels No.:	19/8565	01 02 03
Date:	Box No.:	22.05.2019	01
Quantity good pcs:		6000	
Quantity bad pcs:		40	

Figure 12: Example of Label per shipment box

Additionally each reel is labeled with an information label about correct storage of RFID labels. The data shown on these labels might differ from the data in the technical specification. Binding are only data on the technical specification because these consider the different materials used for the specific RFID label.

9 Storage and handling



Please note:

RFID labels are electronic devices which are sensitive to mechanical shocks and electrostatic discharge. Handle the reels with care and don't drop them. Control the electrostatic charging during unwinding process.

Always keep the RFID labels in their original box to protect them against pollution and damage. Before usage, the RFID labels should be acclimated to the room conditions.

Warranty, Liability and Compliances

LUX-IDent RFID labels are thoroughly tested. It is the responsibility of LUX-IDent's customers to evaluate their use case for compatibility with the LUX-IDent RFID label properties and to ensure through appropriate process controls that the determined machine and material parameters are met on an ongoing basis. LUX-IDent does not accept warranty claims for material that has already undergone further processing.

The technical performance of LUX-IDent RFID labels in regards to read/write distance, memory size and security functions is depending on the selected chip. LUX-IDent assumes neither liability nor responsibility for the technical performance and specification of the RFID chip used in the RFID label.

LUX-IDent reserves the right to make changes to its products or services or to discontinue any product or service at any time without notice, as long as there are no specific obligations with specific customers.

LUX-IDent provides customer assistance in various technical areas, but does not have full access to all data concerning the use and applications of customer products. Therefore LUX-IDent assumes no liabilities and is not responsible for customer applications or product or performance relating to systems or applications incorporating LUX-IDent products.

LUX-IDent assumes no liability and is not responsible for infringement of patents and/or any other intellectual or industrial property rights of third parties, which may result from assistance provided by LUX-IDent.

LUX-IDent products are not designed, intended, authorized or warranted to be suitable for life support applications or any other life critical applications which could involve potential risk of death, personal injury or severe property or environmental damage.

LUX-IDent products are fully compliant to actually set industry rules, like RoHS, REACH and RED. Actual versions of the compliances certificates are available on request.



General RFID label Delivery and Packaging specification

10 Document revisions

Date	Revision	Status, modifications
22.05.2019	1.0	Initial release
25.06.2019	1.1	Standard tape configuration without empty positions Update at splicing positions Failure correction at reel drawings



LUX-IDent s.r.o. – headquarters

(production, sales, R & D)

Tovární 368, 563 01 Lanškroun, Czech Republic

Tel.: +420 465 352 500

LUX-IDent Germany GmbH – branch office

(sales, R & D)

Rudolf-Diesel-Ring 21, 82054 Sauerlach, Germany

Tel.: +49 8104 805 500

Please direct your enquiry to: **smart-inlays@lux-ident.com**

www.lux-ident.com